

仕様 SPECIFICATIONS	
割出精度 INDEXING ACCURACY	20 sec以内
再現精度 REPEATABILITY	4 sec以内
テーブル最高回転速度 MAXIMUM ROTATION SPEED	16.6 min <sup>-1</sup> [モータ MOTOR 2000 min <sup>-1</sup> ]
クランプトルク CLAMPING TORQUE	1200N・m [静圧 PNEUMATIC 0.5MPa]
許容最大空圧力 MAXIMUM PNEUMATIC PRESS	0.7 MPa
許容積載質量 ALLOWABLE MASS OF WORK	横 350 kg 立 180 kg
許容積載ワーク径 ALLOWABLE WORK DIA.	φ320 mm
総減速比 TOTAL REDUCTION RATIO	1/120
製品質量 MASS OF ROTARY TABLE	142 kg
回転モーメント慣性モーメント MACHINE INERTIA (REFERRED TO MOTOR SHAFT)	0.00032kgm <sup>2</sup>

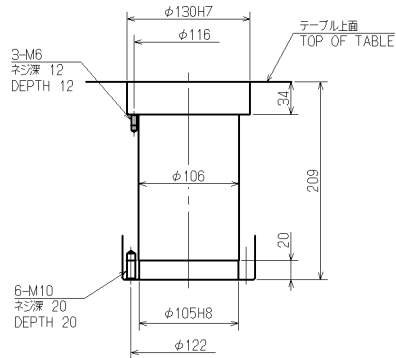

スピンドル穴  
SPINDLE THRU-HOLE

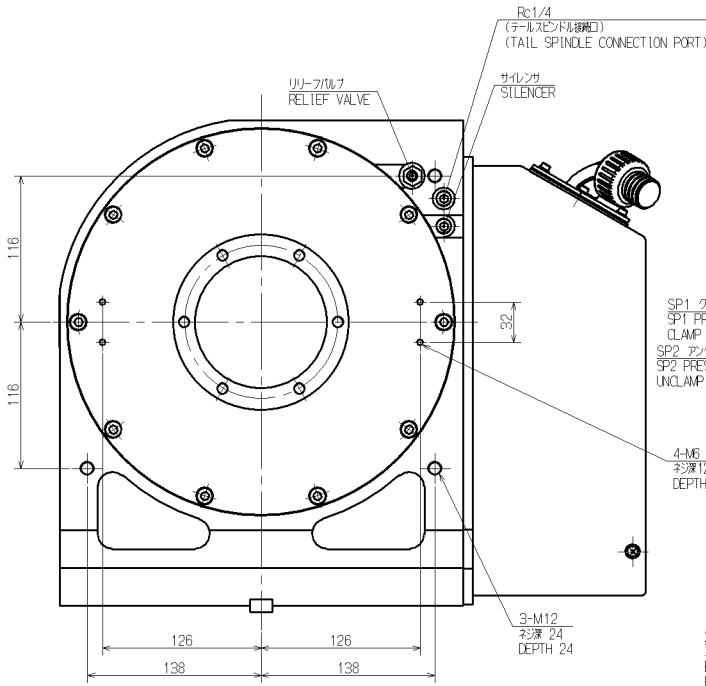
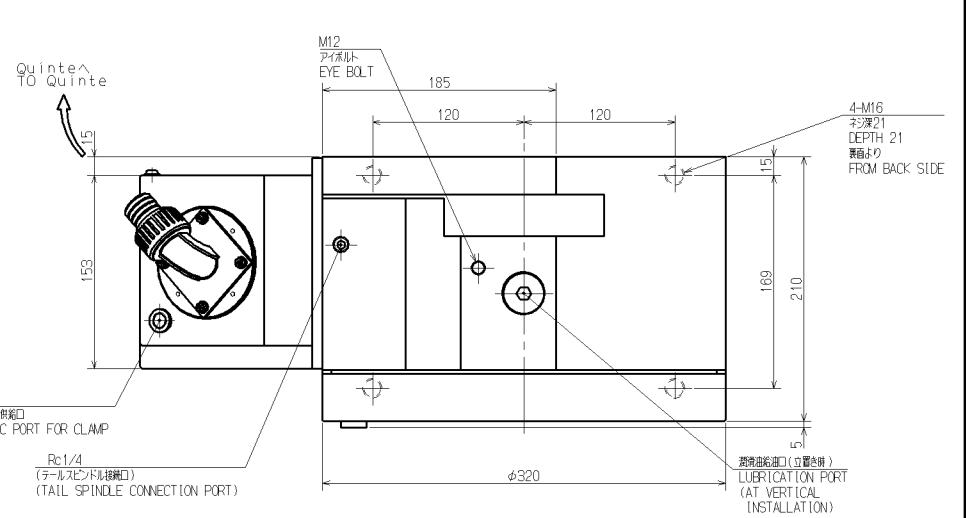

SP1 クランプ検出圧スイッチ  
SP1 PRESSURE SWITCH FOR CLAMP DETECTION  
SP2 アンクランプ検出圧スイッチ  
SP2 PRESSURE SWITCH FOR UNCLAMP DETECTION

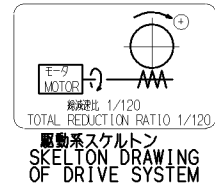
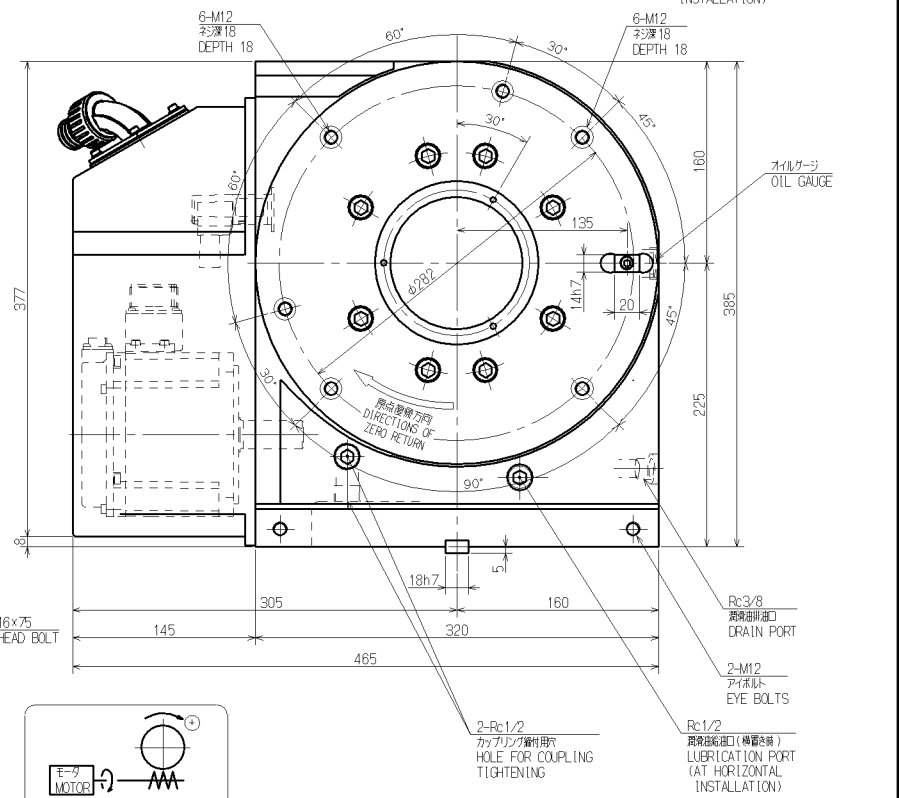
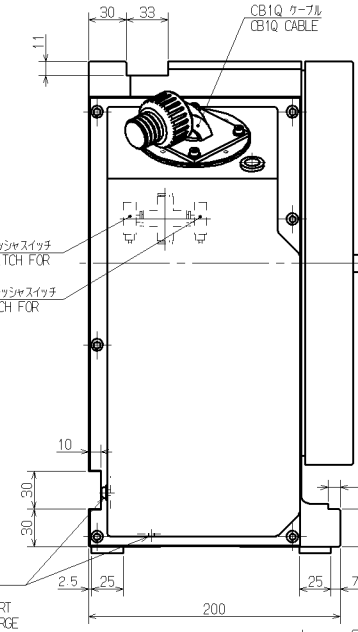

クランプ器具 付属品 4組  
CLAMPING PARTS ACCESSORY 4 PAIR

CAREER			SCALE	TYPE	MR320LAV00	WEIGHT	kg
MANAGER	CHIEF	DRAWN BY	1:3	NAME	NCテーブル NC ROTARY TABLE		
			3RD ANGLE	MR320LAV00 ガイガイ OUTSIDE VIEW			
KITAGAWA IRON WORKS CO.,LTD.		DATE	DRW NO.		61E 27 0057 0		